

EXHIBITOR MANUAL

Welcome to all the exhibitors to the Forum Acusticum Congress at Politecnico di Torino! This manual provides important information and guidelines to facilitate your involvement and ensure a positive experience during the event.

VENUE

Politecnico di Torino

Via Paolo Borsellino, 28-44, 10138 Torino

Website: <https://www.fa2023.org/congress-venue/>

ORGANIZING SECRETARIAT

Centro Congressi Internazionale S.r.l. a Socio Unico

Via G. Guarini, 4 – 10123 Torino (TO) – Italy

Sponsors contact person:

Federica Robino

Tel. +39 011-2446935 M +39 389-6332266

E-mail: sponsor@fa2023.org

Website: www.ccicongress.com

MATERIAL SHIPPING DETAILS

Exhibitors should make sure that a representative will be at the stand with the goods as the organizers will not accept or sign for any goods, exhibits or other materials on behalf of any exhibitor.

The items for the stands cannot be shipped previously to the conference venue.

DEADLINES

Booth reservations: **by July 21st, 2023**

Graphic files for the booth: to be sent **by July 26th, 2023**

Regular participant registration: **by August 31st, 2023**

SHELL SCHEME GRAPHICS

The deadline for sending graphics files is set on **Wednesday 26th July** (strict!). The files should have the following characteristics:

- files including allowances and print marks
- .pdf format – 150 dpi resolution, 1:1 scale (300 dpi resolution for 1:2 scale)
- CMYK four-colour process

The graphics are valued 60,00 € per square meter. Each panel graphics on the back of the shell scheme measures 96,7xh239,8 cm. Please kindly note that the visible part will be 95xh238 cm. Whereas the 2 lower corner panel graphics measures 96,7xh96,7 cm and the visible part will be 95xh95 cm.

You will find below the images indicating the measurements of the graphics for each stand.

EXHIBITION TIMES

Set-up

Sunday, Sept. 10th, 2023, from 09:00 AM to 03:00 PM

Shell scheme will be assigned based on the size of your booth and the specifications indicated in your registration.

Please adhere to the setup time and ensure that your booth is ready before the start of the congress.

Positioning and Layout:

A floor plan of the exhibition area will be provided, indicating the location of your booth.

Promotional materials and products should be placed within your assigned space.

Ensure that your booth is organized in a tidy and attractive manner, adhering to safety measures.

Services and Equipment:

The following standard services and equipment will be provided for each shell scheme: 1 table, 2 chairs, electrical power supply (max 500w), basket.

Any additional requests for special services or equipment should be communicated in advance to the congress organizers and may incur additional costs and it is subject to availability.

Please find the example below:

Stand 3x2- open on the front

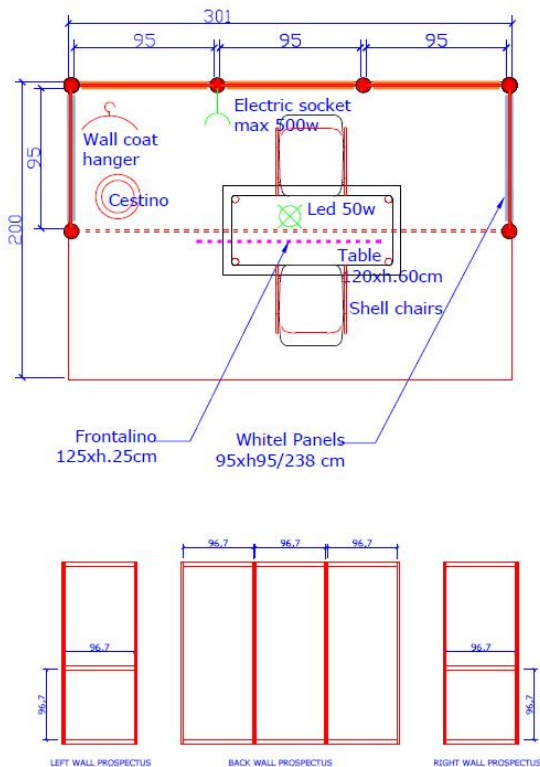

Exhibition Area

From Monday, Sept. 11th to Friday, Sept. 15th, 2023, from 08:30 AM to 06:30 PM

Precise timings of the congress will be communicated later along with the official program.

Please ensure that your booth is always open and operational during the congress opening hours to maximize interaction with participants.

Safety and Liability:

It is the exhibitor's responsibility to ensure that their materials, products, and equipment are safe and do not pose any risks to the safety of participants or staff.

The congress organizers disclaim any responsibility for any damages, theft, or loss of exhibitor property.

Dismantling

Friday, Sept. 15th, 2023, from 04:00 PM to 07:00 PM

Please adhere to the designated dismantling time and remove all materials and products from your booth. Waste should be properly disposed of in the designated containers and trash baskets.

We kindly request all exhibitors to read this manual carefully and adhere to all instructions provided. If you have any questions or require assistance, please do not hesitate to contact us at sponsor@fa2023.org

We wish all exhibitors a successful Forum Acusticum Congress at Politecnico di Torino!

Kind regards,

FA2023 Congress Secretariat

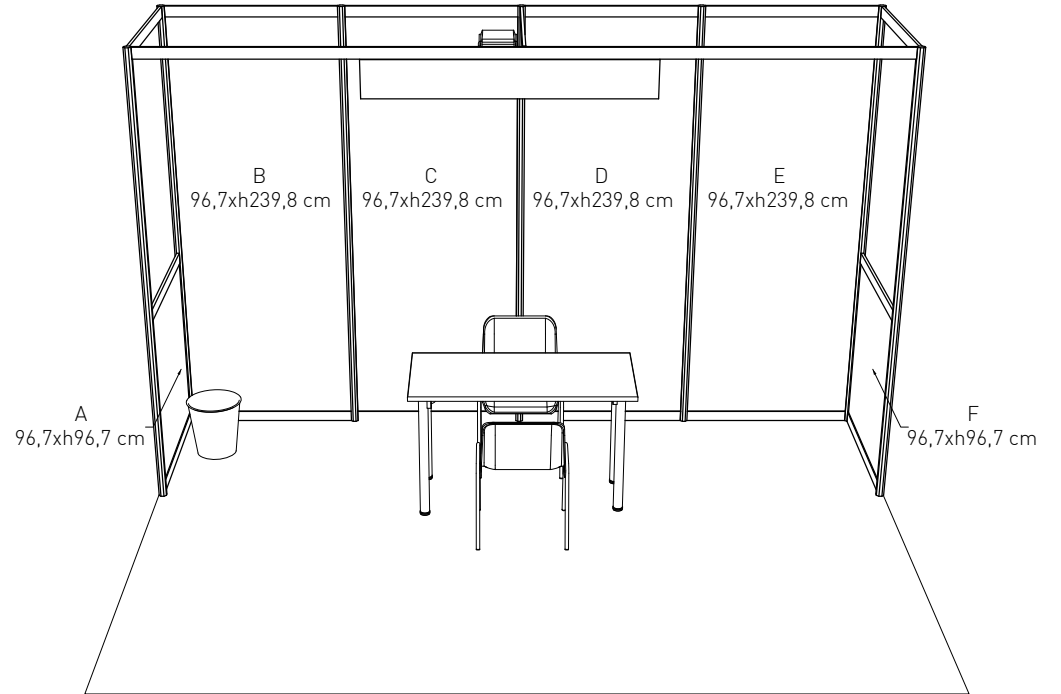
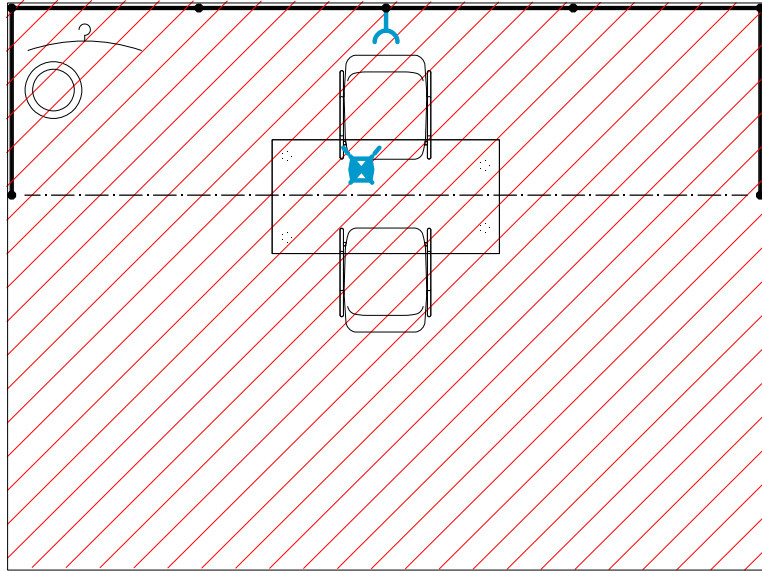

Scala 1:40 Quote in cm
0 0,5 1 1,5 m



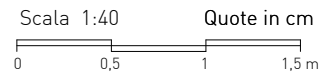
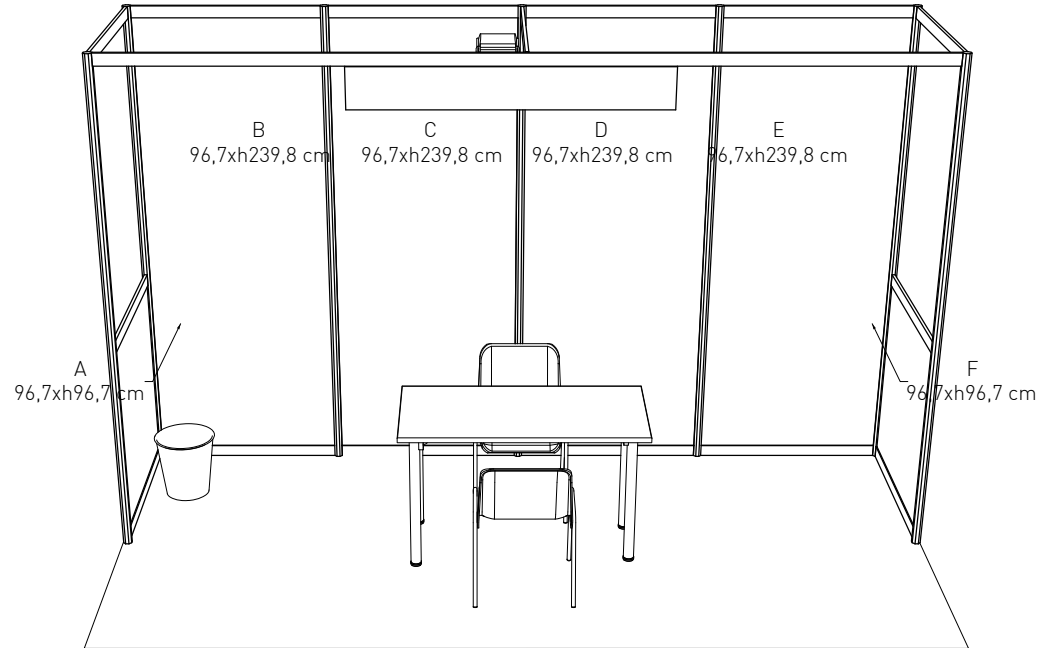
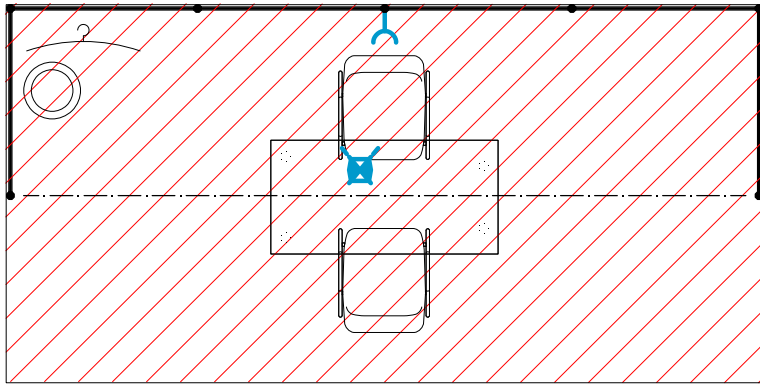

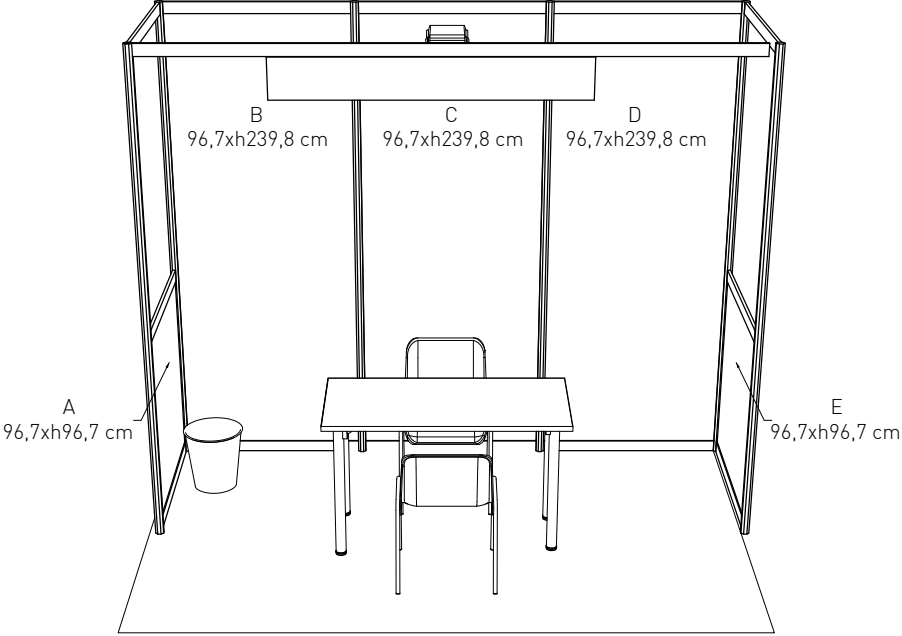
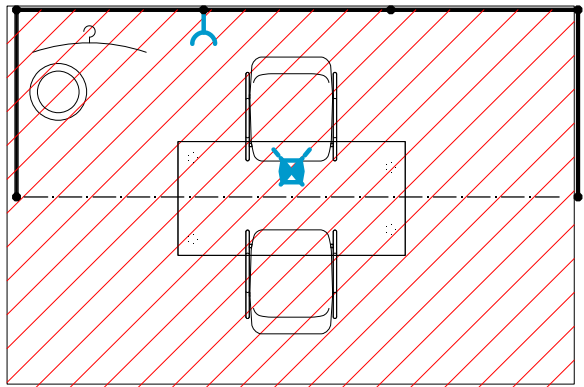

Scala 1:40 Quote in cm
0 0,5 1 1,5 m